

Judging from the response to the original article, a lot of you want to take it one step further. W1FB shows us how to use our VFO project to drive some of the older rigs.

VFO Interfacing

Using Solid-State VFOs To Drive Vacuum-Tube Transmitters

BY DOUG DEMAW*, W1FB

My June 1991 *CQ* article concerning stable VFO design stimulated an unexpected reader response. Notable among the questions asked was "How can I interface a semiconductor-type VFO to the input of my older, tube-type transmitter?" It is a technique that I have taken for granted in recent years, not realizing that the less-experienced amateur might need guidance toward doing the job effectively. It seems that a number of amateurs are using old AM CW transmitters that either lack a VFO or contain one that is quite unstable. Certainly, a stable outboard solid-state VFO is capable of solving their problems. This article provides tips for using a solid-state VFO with a tube style of rig.

Some Limitations

It is important to understand that transmitter amplifiers have a low input and output impedance characteristic. Conversely, most vacuum tubes exhibit high input and output impedances (grounded-grid amplifiers being the exception). Although a semiconductor amplifier can produce significant output power, the voltage developed across, say, a 50 ohm load is relatively small. For example, a 1 watt transistor amplifier can produce an RMS voltage of 7 across 50 ohms. That same watt of power will provide 31.6 RMS volts across a 1000 ohm load. A vacuum-tube grid requires a fairly large voltage swing in order to excite the tube properly—30 to 50 volts is typical for a small triode or pentode. Fortunately, power is not needed in large measure to drive the grid

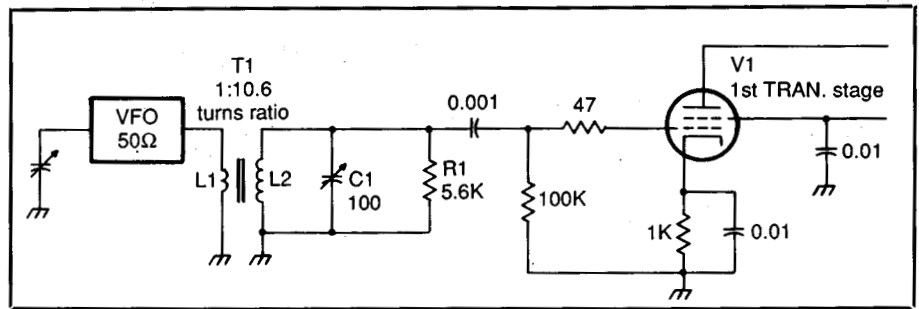

Fig. 1—A method for connecting a LO-Z solid-state VFO to a transmitter input stage that uses a tube. T1 is tuned to the operating frequency by C1. R1 provides a load for the VFO and broadens the response of the C1/L2 tuned circuit. A T1 step-up ratio is required to ensure ample voltage swing at the V1 grid.

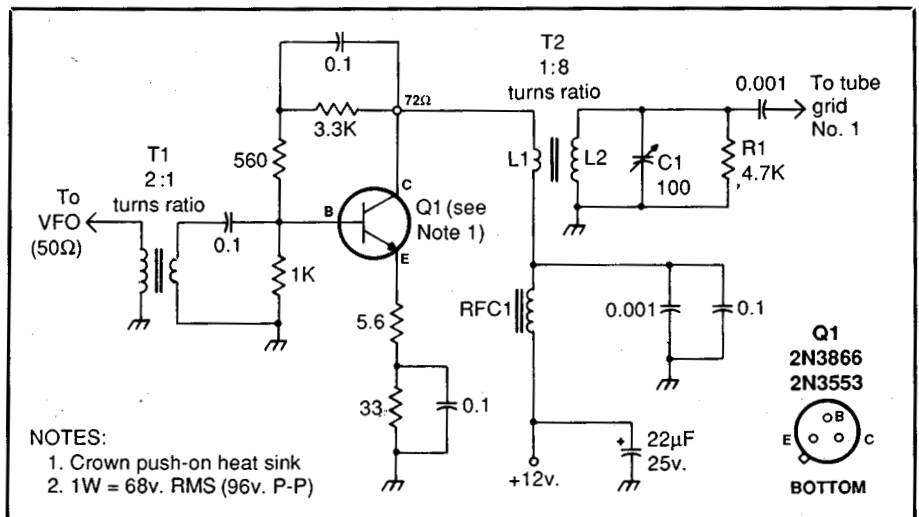

Fig. 2—A solid-state VFO amplifier that can produce up to 1 watt of output with 75 mw or greater driving power. C1 and L2 are tuned to the operating frequency. T1 has 12 primary turns of no. 26 enameled wire on an Amidon Associates FT-50-43 ferrite toroid. The secondary has 6 turns of no. 26 enameled wire. R1 is a 1 watt carbon resistor. RFC1 has 8 turns of no. 26 enameled wire on an Amidon FT-23-43 ferrite toroid. T2 is wound for the operating frequency.

*P.O. Box 250, Luther, MI 49656

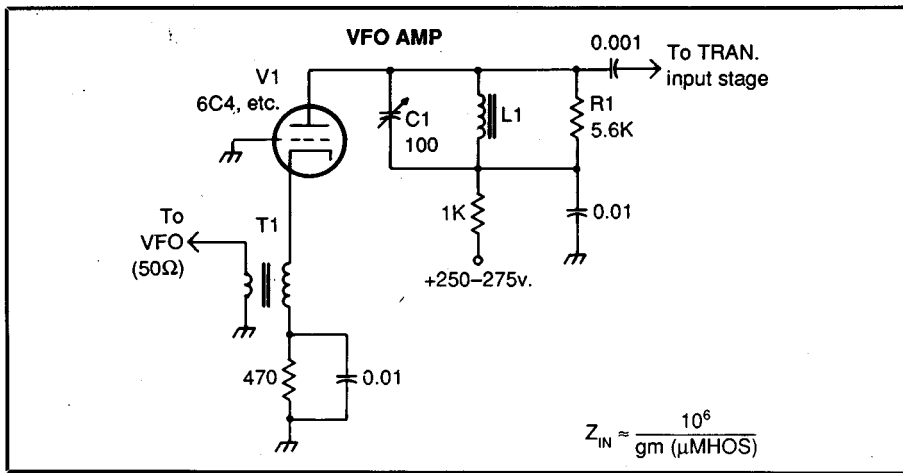

Fig. 3—A grounded-grid tube amplifier for boosting the VFO output power. The turns ratio of T1 is based on the equation, once the gm in μmhos for V1 is determined from a tube manual. C1 tunes L1 to the operating frequency.

of a low-level tube amplifier. Therefore, with correct interfacing methods we can use a solid-state VFO to provide an operating frequency for a tube transmitter or receiver.

Maximum power transfer cannot occur in any electrical circuit unless unlike impedances are matched by some means. The most common approach to this requirement is the employment of a tuned or untuned matching transformer, although capacitive voltage dividers are also suitable in some circuits. An untuned, broadband transformer at the output of a solid-state amplifier is seldom practical in terms of spectral purity. This is because semiconductor amplifiers generate high levels of harmonic current by means of envelope distortion and nonlinear parametric action in the transistor junction.

Transistors are much worse than vacuum tubes in this regard. It is not unusual to find the second and third harmonics at the transistor collector (untuned output network) only 10 to 15 dB down from the peak output of the desired frequency. Harmonic filters are almost mandatory at the output of transistor amplifiers. Therefore, if you use a broadband matching transformer between a solid-state amplifier and a tube grid, a harmonic filter should be included in the line. Alternatively, you may use a tuned (narrow band) matching transformer to interface your solid-state VFO to your tube rig. This will minimize the transfer of unwanted harmonic currents.

Practical Matching Methods

Fig. 1 shows one method of connecting a solid-state VFO to a vacuum tube. If V1 is arranged as a crystal oscillator, you will need to remove the feedback capacitors and use the stage as an amplifier. If not, V1 may self-oscillate when the VFO is

connected to it. L1 is a low-Z link that couples the VFO to the C1/L2 tuned circuit, which is peaked at the desired operating frequency. L2 may be a slug-tuned inductor and C1 can be a fixed-value capacitor. R1 lowers the Q of L2 and establishes a 5.6K ohm load for the VFO. R1 broadens the tuned-circuit response to lessen the need to retune it when QSYing from one end of the band to the other. I described a VFO with sufficient output power to permit you to use the fig. 1 circuit (see June 1991 CQ). This circuit needs an amplifier after it, such as the circuits shown in figs. 2 and 3.

Fig. 2 shows a class A linear amplifier that is suitable for elevating the VFO output power to 1 watt. A 2N3866, 2N1553, or MPS-U02 may be used for Q1. Any high fT NPN transistor that is similar to those listed will work in this circuit. Alternately, you may use four 2N2222As or 2N4400s in parallel for Q1.

T1 in fig. 2 is a 4:1 broadband transformer that matches a 50 ohm VFO to Q1. The impedance ratio should be increased to 10:1 for VFOs that have a 500 ohm output impedance. This calls for a 7:1 turns ratio. C1 and L2 form a tuned circuit for the operating frequency. R1 broadens the frequency response of the tuned circuit and provides a workable load for Q1. An impedance step-up of 1:8 is required for T2, owing to the Q1 collector impedance of 72 ohms.

You may wish to consider the fig. 3 circuit if you're disposed to using tubes as amplifiers. This grounded-grid amplifier may be used between the solid-state VFO and the input stage of your tube-type transmitter. The equation in the diagram, based on the transconductance of the tube used, provides a close approximation of the input impedance of the V1 cathode. A broadband matching transformer (T1) is used at the amplifier input, whereas a tuned circuit (C1/L1) is utilized

at the amplifier output port.

You will need to develop your own tuned-circuit values. The C-to-L ratio of the tuned circuits is not critical provided you adhere to the impedance ratios specified. C1 in the tuned circuits can be a 100 or 150 pF variable capacitor for the bands from 1.8 to 7 MHz. Use a 50 or 75 pF variable from 10 MHz through the 10 meter band.

VFO Isolation Is Important

Your solid-state VFO should be contained in its own shielded box. Keep this unit outboard from the tube transmitter because the heat within the transmitter cabinet will surely cause long-term drift. A shielded enclosure for the VFO is important in the interest of preventing stray RF from entering the VFO circuit. Stray RF currents can disrupt VFO performance, which may result in frequency jumping and drift. I suggest also that you use shielded cable for the +12 volt power leads that connect to the VFO. Likewise for the on-off control lead for the VFO.

In Summary

The information I have provided here is anything but profound. These tips should, however, head you down the road of success when you mate your solid-state VFO to your tube rig.

